

維盟科技有限公司
EVOwave Technology Co., Ltd.

規格書 / Specification

Description:	SMT Type Vibrator
Part No.:	VK0467MXX
Date:	2015.4.13

地址: 新北市汐止區康寧街 169 巷 27 號 10 樓之 1

Address: 10F-1, No. 27, Lane 169, Kang-ning St., Xizhi district 221, Taipei, Taiwan.

Tel: 886-2-2692-6058

Fax: 886-2-2692-6659

1. 實用範圍 Application

本說明書適用於圓柱鐵芯貼片馬達 **VK0467MXX**型

This specification applies to Cylindrical core SMT Motor **VK0467MXX** model

2. 結構形式 Construction-form

序號 NO.	項目 Item	內容 Contents
2-1	電機結構 Motor construction	4mm×3mm的鐵芯貼片馬達 4mm×3mm cylindrical core SMT motor
2-2	磁極極數 Number of magnet poles	2 極(磁鋼內置) 2-poles (inner magnet type)
2-3	換向方式 Rectifying method	金屬電刷換向器裝置 Metal brush and commutator

3. 標準使用條件 Standard operating condition

序號 NO.	項目 Item	規格 Specification	條件/備註 Condition / Remark
3-1	額定電壓 Rated voltage	2.7V	加在端子兩端的電壓 Added to both ends of the terminal voltage
3-2	額定負荷 Rated load	振子 (R1.7 T=2.8) eccentric weight	振子重量約等於 0.24g eccentric weight is about equal to the weight of 0.24g.
3-3	旋轉方向 Rotation direction	順時針方向 CW	從輸出端看，並且電壓正極接端子正極 When viewed from output side with +ve voltage applied to +ve terminal
3-4	擺放位置 Motor position	任意位置 Any position	
3-5	工作電壓範圍 Voltage range for use	DC 2.3V~3.2V	
3-6	使用環境 Operating conditions	-20°C~70°C 0%~95%RH	常規濕度/ordinary humidity 不凝露/no condensation of moisture
3-7	貯存環境 Storage conditions	-40°C~85°C 0%~95%RH	常規濕度/ordinary humidity 不凝露/no condensation of moisture/

4. 產品測試環境條件 Environmental Test Conditions

序號 NO.	項目 Item	測試環境條件 Environmental condition
4-1	溫度 Temperature	20±2℃
4-2	濕度 Humidity	60±5% RH
4-3	電機體位 Motor Position	軸伸水準 Shaft Horizontal
4-4	電源 Power Supply	直流穩壓電源/DC Power Supply DC2.7V±2%

備註：所有的資料在溫度 20±2℃，濕度 60±5% RH 的條件下測定。在對判定不發生異議時，也可在溫度 5~35℃，濕度 45~85%RH 的環境下測試。

NOTE : All data shall be based on the measurement under the temperature 20±2℃ and humidity 60±5% RH, however the range of temperature 5~35℃ and humidity 45~85%RH if there is no doubt about the judgment.

5. 機械特性 Mechanical Characteristic

序號 NO.	項目 Item	測試環境條件 Environmental condition	規格 Specification
5-1	外觀尺寸 Configuration	遊標卡尺 Vernier caliper	參考外形圖紙 As specified in outline drawing
5-2	外觀 Appearance	目測 Visual examination	無明顯機械劃痕、裂縫、鏽跡、污點 No obvious evidence of mechanical damage、crack、rust and stain
5-3	重量 Weight	架盤天平 精度 0.1g Plate balance 0.1g	0.6g (Approx) (左右)
5-4	軸向間隙 Shaft end play	遊標卡尺或百分表 Vernier caliper or Dial indicator	(0.05- 0.3) mm
5-5	振子固定力 Holding strength Of eccentric weight	測力計/Pulling force testing machine	50N (5.6kgf) Min

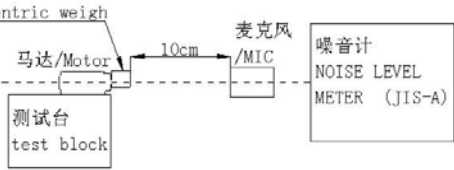
5-6	機械雜訊 Mechanical Noise	 <p>測試場地：類半自由聲場 額定電壓，空載運行，背景雜訊≤ 20 dB(A),電機固定在測試夾具上(軸伸水準)，拾音器沿軸向正對電機平面，距離10 cm。Test site: Class of semi-free field At rated voltage and free load, Back ground noise : 20 dB(A) Max, Fix the motor in a test jig (Shaft Horizontal). Microphone is faced to the flat of motor and recedes by 10cm</p>	≤ 50 dB(A)
-----	--------------------------	---	-----------------

6. 電氣性能 Electrical characteristics

序號 NO.	項目 Item	測試環境條件 Environmental condition	規格 Specification
6-1	額定電流 Rated current	在額定電壓及標準負荷（振子）下，5秒後讀數。	85mA Max
6-2	額定轉速 Rated speed	Read the data at rated voltage and rated load(eccentric weight)after 5S.	14000 \pm 2500 r. p. m
6-3	堵轉電流 Stall current	在額定電壓及標準負荷（振子）下，2秒後讀數。 Read the data at rated voltage and rated load(eccentric weight)after 2S.	95mA Max
6-4	起動電壓 Starting voltage	在額定負載（振子）下電樞的任意位置。 At rated load (eccentric weight) any position of rotor.	2.3V DC Max
6-5	端子阻抗 Terminal resistance	在 20 \pm 2 $^{\circ}$ C 下 At 20 \pm 2 $^{\circ}$ C	32.0 Ω \pm 6. 0 Ω
6-6	絕緣電阻 Insulation resistance	在 50V 直流下，導線和機殼間 At DC 50V between lead wire and case.	1M Ω Min

7. 信賴性試驗 Reliability Test

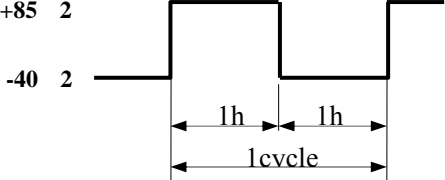
序號 NO.	項目 Item	試驗條件 Test condition	判定基準 Requirements
7-1	壽命測試 Life test	電壓/Voltage : 2.7VDC 負荷/Load : 振子/ eccentric weight (R1.7 T=2.8 約 0.24g) 溫度/Temperature/20±2°C 相對濕度/Relative humidity : 60~70%RH 將馬達固定在試驗臺上 (軸向) /Lock the motor in a test fixture (Shaft horizontal) 試驗方法 1/Test mode1: 連續運轉至少 10 小時/10hrsnet running time 試驗方法 2/Test mode2: 一個週期, 開 2.5 秒, 關 2.5 秒; 共 200000 個週期/1cycle, 2.5sec ON, 2.5sec OFF ; 200000 cycles totally	在常溫常濕下放置 4h 後, 馬達應符合項 8-1、8-2 的要求。 After 4 hours exposure in ordinary temperature and humidity, Motors shall be approved as specified in item 8-1、8-2.
7-2	低溫放置 Low temperature storage	溫度/Temperature: -40±5°C ; 時間/Time: 96h 濕度/Humidity : 常濕/ Ordinary Humidity	在常溫常濕下放置 4h 後, 馬達應符合項 8-1、8-2 的要求。 After 4 hours exposure in ordinary temperature and humidity, Motors shall be approved as specified in item 8-1、8-2.
7-3	高溫放置 High temperature exposure	溫度/Temperature: +85±5°C ; 時間/Time: 96h 濕度/Humidity : 常濕/ Ordinary Humidity	
7-4	濕度測試 Humidity test	溫度/Temperature: +40±5°C ; 時間/Time: 96h 濕度/Humidity : 90±5%RH	
7-5	振動 Vibration	全振幅 /Displacement :1.5mm (p-p) 頻率/Frequency:10 to 55Hz 週期/Period :20min範圍內 (10~55~10Hz) /20 Minutes log sweep (10~55~10Hz) 方向/Direction:x、y、z 時間/Time:每 2h/Each 2 hours	測試結果應符合項 8-1、8-2、8-3 的要求。 After the test motors shall be approved as specified in item 8-1、8-2、8-3.
7-6	熱衝擊試驗 Thermal Shock test	溫度Temperature : -40°C~ 85°C 時間Time : 2h 迴圈週期數Circle cycle : 30cycles 	測試結果應符合項 8-1、8-2 的要求。 After the test motors shall be approved as specified in item 8-1、8-2.

7-7	跌落試驗 Drop test	方向Direction : x,y,z 高度High : 1.5m 跌落次數: 每個方向各 2 次 Times : 2 times each direction 試驗狀態: 將電機放在重約 100 克的剛性較好的塑膠盒子裏, 自由地跌落至混凝土地面上 Test state: The motor is set into a rigid cubic plastic housing approximately weight 100g and fall free on the concrete floor	試驗結束後, 電機應滿足 8-1、8-2、8-3 的規定 After having finished the test, the motor should conform to the requirements of the items 8-1、8-2、8-3.
-----	-------------------	--	--

8. 信賴性試驗後的要求 Requirement After Reliable Test

序號 NO.	項目 Item	規格 Specification
8-1	額定轉速 Rated speed	初始值±30% Initial data±30%
8-2	額定電流 Rated Current	初始值±35% Initial data±35%
8-3	起動電壓 Starting voltage	≤ 2.3V

9. 包裝要求 Package Require

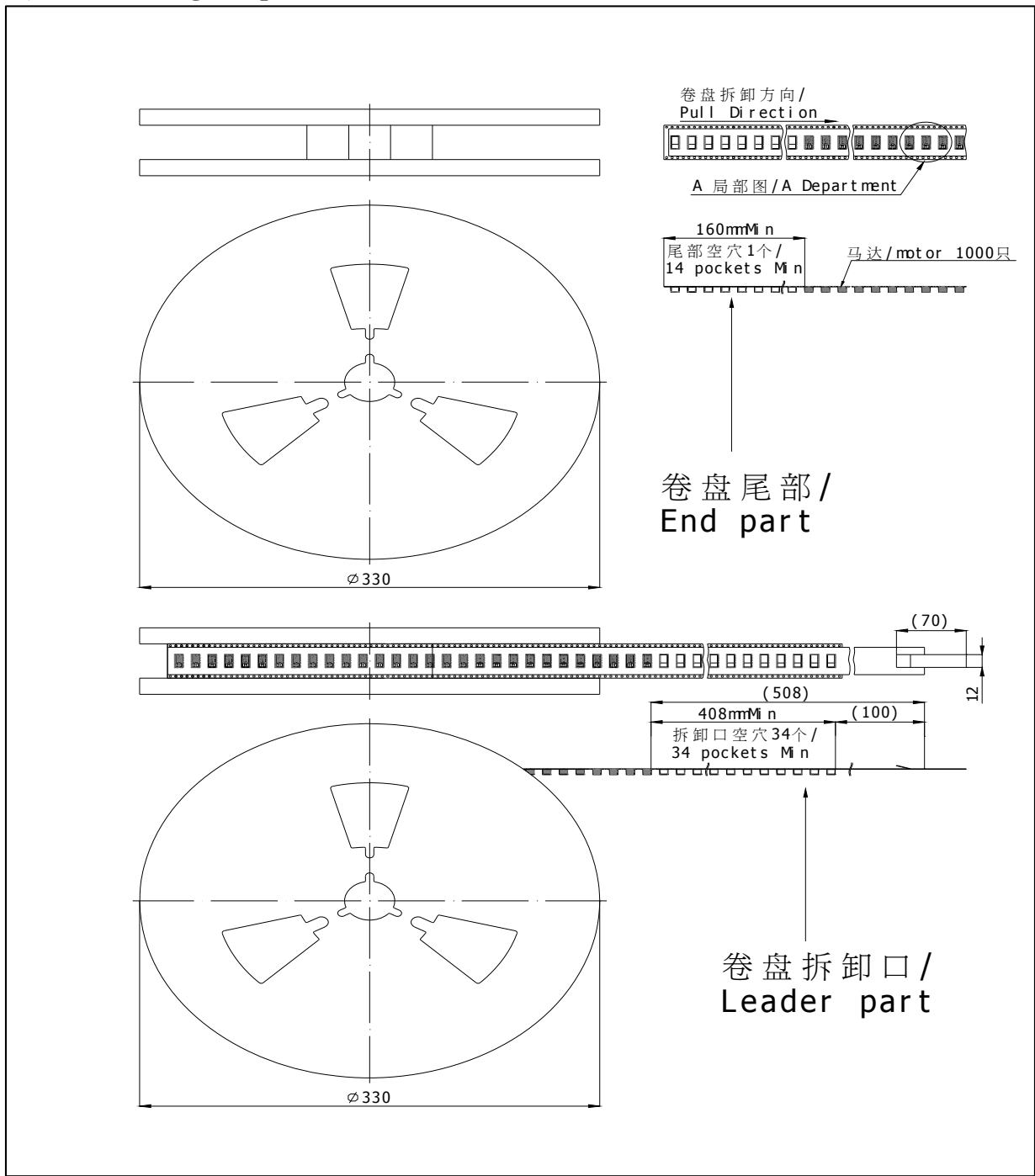

9-2 最終包裝 Final Packaging

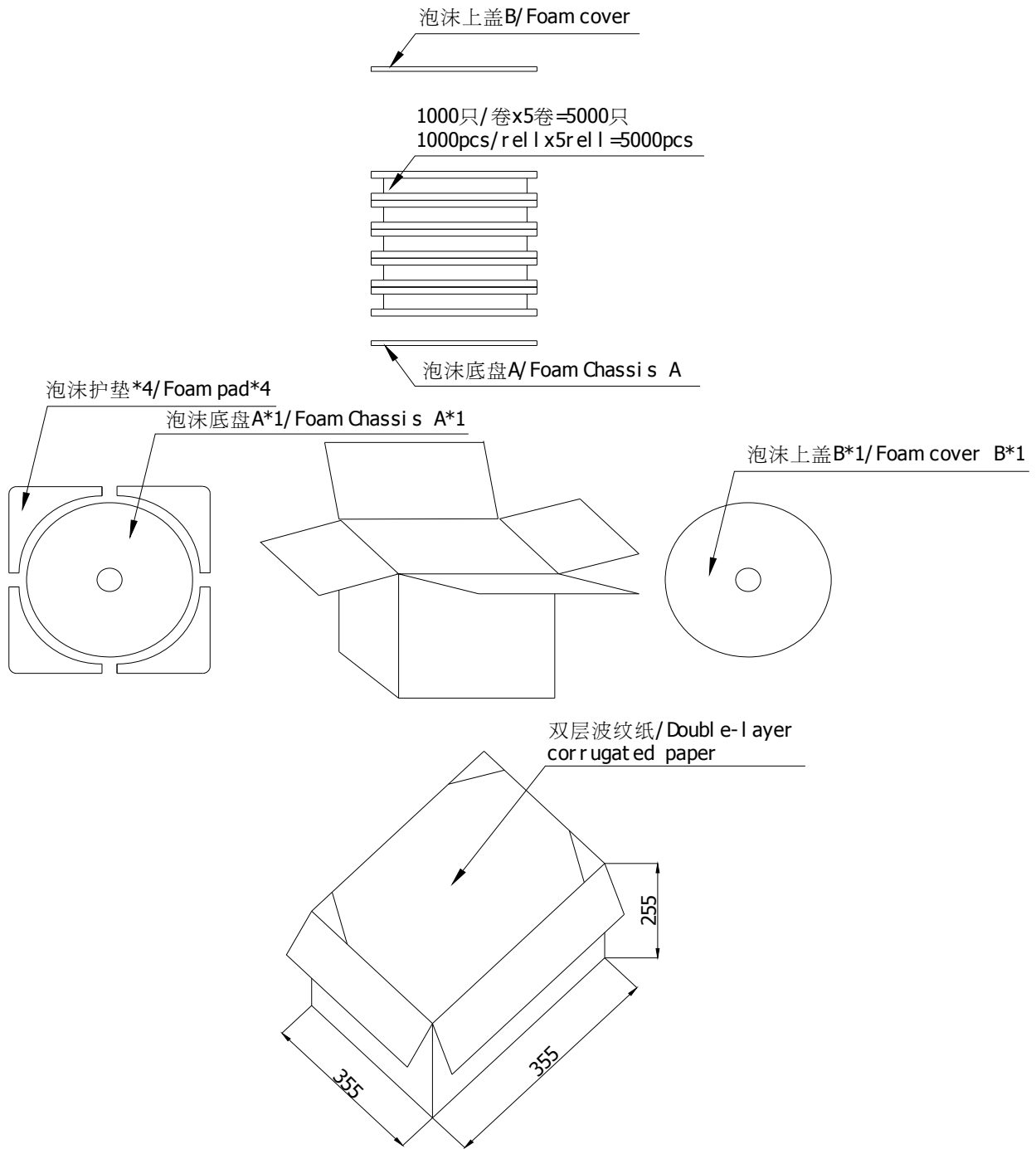

10. 注意事項 CAUTIONS

1) 使用容差 ALLOWABLE RANGE FOR USE

注意電壓及電流的使用範圍，並且在本標準規定情況下使用電機，否則將相應降低電機的使用壽命和性能。

Pay attention to voltage and current ranges for use ,and use the vibration motor in the condition accordance with this specifications ,or the life and performance should be considerably reduced.

2) 移動電機 MOVE YOUR MOTOR

拿電機時，應輕拿輕放，應盡可能地利用外殼部分

請勿將其跌落或加以超過 5 公斤的壓力。否則會引起電機的外部形態和電氣特性的改變

Please deal with the motors gently, you should make use of the outer case as possible as you can.

Do not press the product with more than 0.5 kgf or drop it. It can cause the transformation of performance or external appearance.

電機在運輸過程中應小心輕放，避免嚴重碰撞敲擊引起的電機機身和性能受損。

Please lay the motors carefully in transportation to avoid any serious damage to the motor body or its electric function because of collision.

3) 儲存 STORAGE

儲存溫度：-40°C~85°C

儲存濕度：0%RH~95%RH

避免放置在高溫、潮濕的環境中。

Storage temperature：-40°C~85°C

Storage relative humidity：0%RH~95%RH

Avoids storing in high temperature、high humidity

馬達應適當的操作、儲存和運轉環境中均不可存在腐蝕性氣體。例如：H₂S、SO₂、NO₂、CL₂等。另外存儲環境中不可有諸如矽、氰、甲醛水和苯酚等能放射出腐蝕性氣體的物質，在電機的機械構造或裝置中，如果存在腐蝕性氣體，那麼這會引起馬達不運轉。

For proper operation. storage and operating environment must not contain corrosive gases. For example H₂S. SO₂. NO₂. CL₂. etc. In addition storage environment must not have materials that emit corrosive gases especially from silicon. cyanic. formalin and phenol group. In the mechanism or the set. existence of corrosive gases may cause no rotation in motor.

4) 使用電機 HANDLING OF MOTOR

小心拿取、使用。

避免放置在磁性物體附近或接觸其表面，這將影響其功效。

注意操作環境，尤其注意若鐵粉被磁鐵吸附，將出現噪音問題，降低使用壽命

-to handle and hold the vibration motor case softly.

-do not bring magnetized object near or contact with the surface of motor to avoid of performance being deteriorated.

-pay attention to the handling and working environments of motor， because such objects as iron powder if attracted by motor magnet， will cause noise characteristic deterioration, thus reducing the reliability.

請勿靠近磁體或有磁場的裝置存放或運行電機

Please do not operate or store the motor near magnet or magnetic devices.

請在 6 個月內使用，請不要在高溫、低溫、高濕環境下存儲。在使用和打開馬達外包裝時請避免水氣凝結。

Make arrangement to limit the storage period to 6 months or less. Please do not store motor in high temperature. Low temperature. high humidity environment. Condensation of atmosphere must be avoided in motor usage or opening the packaging of the motor.

5) 電機接線 CONNECTION YOUR MOTOR:

不論使用任何方式將您的電源連接到您的電機，請注意不能用過大的力或過高的溫度，否則會造成電機內部零件變形。

Whatever means you are to use to connect your supply to your motor please take care not to use so much force or heat that you cause distortion to components inside the motor.

(1) 電機端子接線： 焊錫溫度：350°C 焊錫時間：1 秒

Motor terminal： Soldering temperature：350°C， Soldering time：1sec.

(2) SMT溫度時間示意圖/Reflow temperature-time diagram

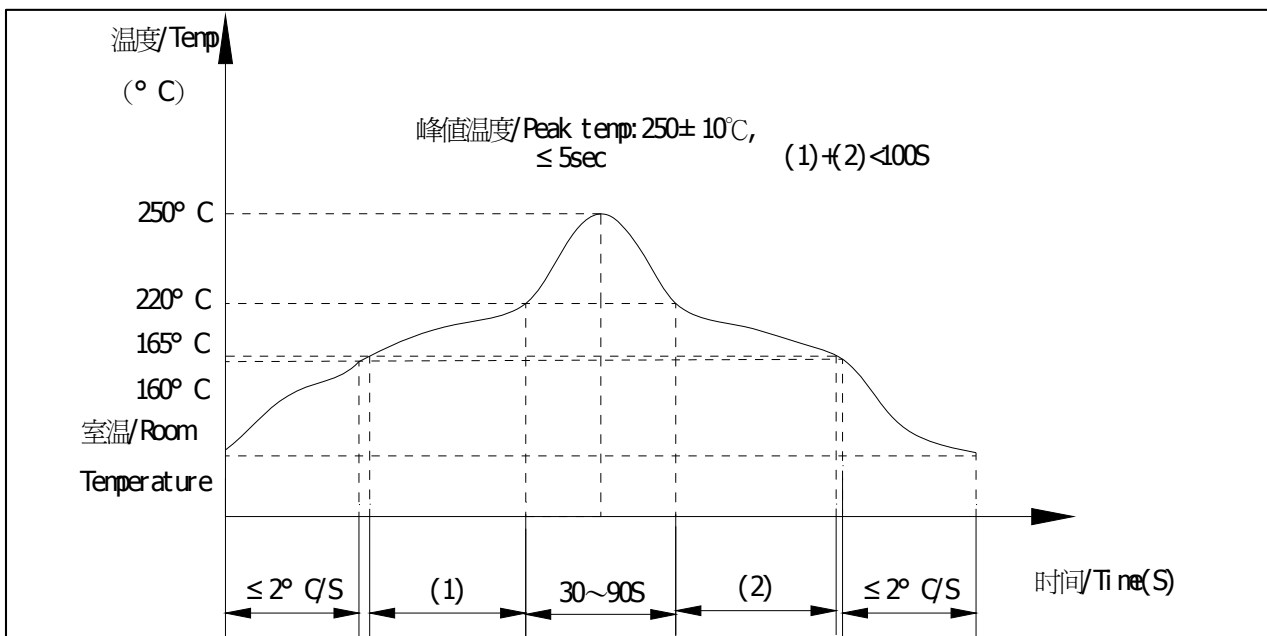

回流焊技術要求/Technical requirements for reflow

焊點最高峰值溫度/Solder joint peak value of temperature：260°C

液態線（220°C）以上時間/At the time of liquefaction temperature of more than：30~90 秒

均溫區要求/Average temperature zone requirements：165°C~217°C < 100 秒

預熱溫區要求/Preheat temperature zone requirements (<160°C)：≤2°C/秒

峰值溫升要求/Peak temperature rise required：1°C~3°C/秒

建議焊錫膏厚度/Suggest solder paste thickness 0.15mm

6) 過負荷 OVERLOADS:

請通電後不要長時間堵住機軸，並且馬達轉動時不要觸碰振子。

Please don't stall the shaft for a long time after powering, and not to touch the weight when motor is rotating.

7) 危險環境 HAZARDOUS ENVIRONMENTS:

我司電機在正常環境中的抗腐蝕能力是符合要求的，但機殼上有少許區域存在的裸露金屬對腐蝕比較敏感，因此未經諮詢請不要在腐蝕環境中儲存或使用電機。

The degree of protection against corrosion on **EVO** motors is satisfactory only for normal environments. There are small sections of the housing in which some bare metal is exposed and is susceptible to corrosion. It is advisable not to store or use motors in corrosive environment without consultation with **EVO**.

8) 其他說明 OTHER

馬達軸向間隙處不應有雜物（如顆粒、纖維物、頭髮、膠帶、膠水等）

There should be no sundries (such as grain, fibre, hair, small tape, glue etc.) in the shaft end play.

9) 請謹記 ALWAYS REMEMBER

維盟科技有限公司擁有一支專業的技術支援團隊，致力於解決我們的電機在新的產品或新的應用中出現的問題，我們樂意與您建立良好的合作關係，我們樂意為您解決使用中遇到的各種問題。

that **Evo** has a professional technical support team for the solution of problems on our motors that used in new products or new applications. We are proud of our good working relationship with our customers and we will be most pleased if we can assist you to find a solution to any problem that you may encounter.

11. 附件 ATTACHMENT

1) 電機外形圖 Motor Outline Drawing

----- END -----

- 1. RATED VOLTAGE: 2.7V
- 2. STALL CURRENT: 95mA (max)
- 3. RATED CURRENT: 85mA (max)
- 4. STARTING VOLTAGE: 2.3V (max)
- 5. RATED SPEED: 14000 ± 2500RPM

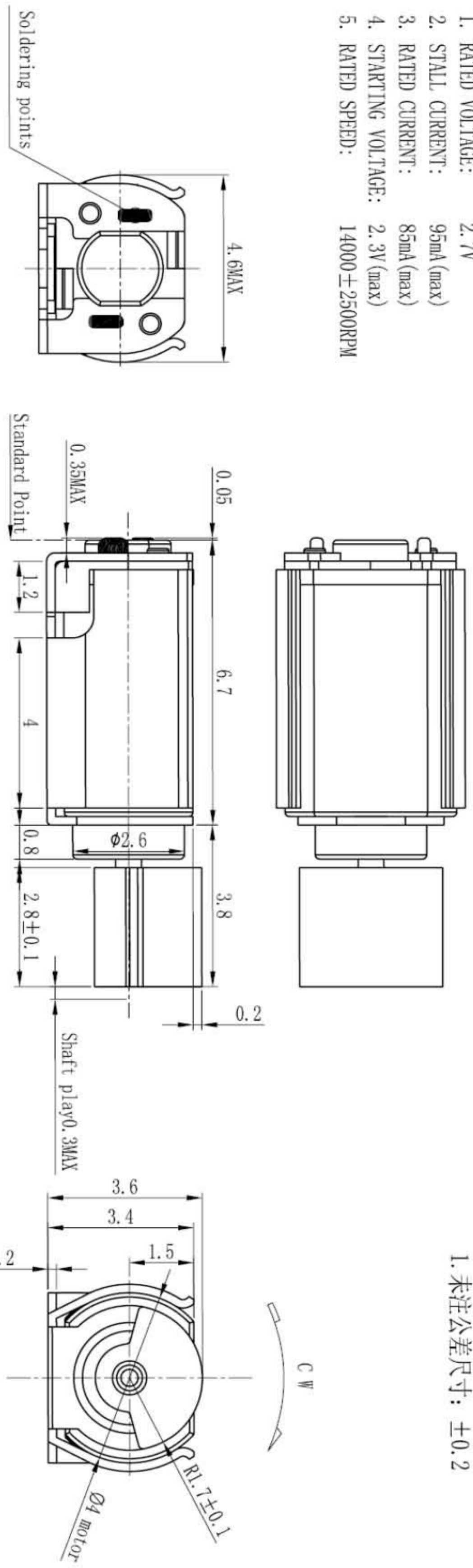

技术要求:
1. 未注公差尺寸: ±0.2

- 比例: 2:1
1. 字体为方正姚体, 字高2mm, 颜色为黑色
 2. "年"表示: 取末位数字 (例如4表示2004年, 以此类推)
 3. "月"表示: [1-9月份用该月数字, 10月用"A"表示, 11月用"B"表示, 12月用"C"表示]
 4. 装配车间(-)用"1"表示, 以此类推;
 5. 日期的表示见下表:

印字	1	2	3	4	5	6	7	8
日期	1	2	3	4	5	6	7	8
印字	9	A	B	C	D	E	F	G
日期	9	10	11	12	13	14	15	16
印字	H	J	K	L	M	N	P	Q
日期	17	18	19	20	21	22	23	24
印字	R	S	T	U	V	W	X	
日期	25	26	27	28	29	30	31	

PCB Layout (Reference)

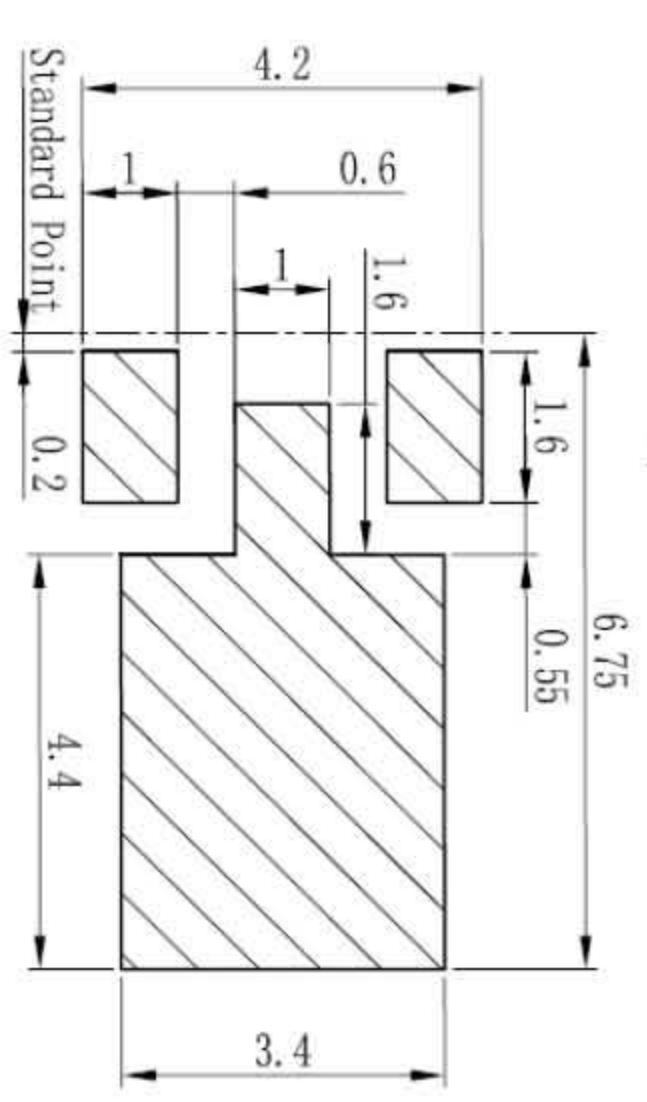

借 (通) 用件 登记
描 图
描 校
底图总号
签 字
日 期

标记	处数	更改内容	签字	日期
设计				
制图				
校对				
工艺				

图样标记	重量	比例
共 张		7:1
第 张		

維盟科技有限公司

外观图

VK0467MXX